



Self-contained Vehicles

# Vehicle inspection guidance

Version 1.0

7 December 2023

# Table of contents

Introduction.....	3
Purpose of this guidance .....	3
The inspection process .....	4
How to read this guidance .....	5
1. Water supply system and loading mechanism.....	6
2. Fixed toilets.....	12
3. Wastewater system and offloading mechanism .....	16
4. Ventilation system.....	20
5 Sink and rubbish storage .....	23
6 Maximum number of occupants.....	25
Appendix 1: Definitions .....	26

## Introduction

Vehicle inspections are a critical part of the self-contained vehicles system. Motor vehicle inspectors (**Vehicle Inspectors**) appointed by a self-containment certification authority (**Certification Authority**) will carry out inspections for that Certification Authority. Certification Authorities will use the findings from a vehicle inspection to help decide whether a vehicle can be certified as self-contained.

The requirements a vehicle must meet to be certified as self-contained are included in the:

- [Plumbers, Gasfitters and Drainlayers Act 2006 \(Act\)](#), and
- [Plumbers, Gasfitters, and Drainlayers \(Self-Contained Vehicles\) Regulations 2023 \(Regulations\)](#)

The requirements are performance-based, rather than prescriptive; they do not specify required tank capacities, pipe diameters, types of fixings or installation methods (for example). Providing guidance on ways the requirements can be met is intended to assist Vehicle Inspectors and Certification Authorities to interpret the requirements and promote high standards and consistency in approaches to vehicle inspections and certifications.

Where appropriate, guidance contained in this document is consistent with or reflects some of the content of New Zealand Standard [5465:2002 \(Standard\)](#) and Schedule 1 of the Building Regulations 1992 ([the Building Code](#)). Neither the Standard nor the Building Code are directly applicable to the self-contained vehicles regime. However, specific technical references and examples used in the Standard and Building Code can be useful in illustrating ways in which vehicles can meet the requirements contained in the Act and the Regulations. This document provides the most relevant guidance for meeting the requirements for a vehicle to be self-contained.

This is the first version of this guidance document. New versions will be published as the self-contained vehicles regime matures.

**Note:** The certification process for self-containment is separate from the processes relating to a vehicle's warrant of fitness or low volume vehicle certification. In particular, any modifications made to a vehicle for the purposes of self-containment (or otherwise) may need a low volume vehicle certification. For more information, refer to Waka Kotahi's website.<sup>1</sup>

## Purpose of this guidance

This vehicle inspection guidance is intended to assist Vehicle Inspectors and Certification Authorities to interpret the requirements contained in the Act and Regulations. It aims to help to determine whether a vehicle's facilities meet the requirements for self-containment by providing guidance and practical examples of ways in which the requirements can be met. It reflects the views of the Plumbers, Gasfitters and Drainlayers Board (**Board**). It does not replace the need for Certification Authorities and

---

<sup>1</sup> In particular, see: <https://www.nzta.govt.nz/vehicles/warrants-and-certificates/modifying-your-vehicle/>.

Vehicle Inspectors to know and comply with the requirements in the Act and the Regulations, and to apply those provisions in carrying out their functions. This information is not exhaustive and may be updated from time to time. If there is any inconsistency between the guidance and the Act and/or Regulations, then the Act and Regulations take precedence.

This guidance has been developed to promote the purpose in the Regulations:

---

To protect the natural environment from contamination and pollution from wastewater and solid waste by ensuring that all certified self-contained motor vehicles provide the minimum facilities required to contain the waste produced by vehicle occupants and ensure occupants have fresh water they need.

---

Vehicle Inspectors and Certification Authorities should keep this purpose front-of-mind when inspecting vehicles and interpreting the various requirements for self-containment. The requirements must be interpreted in a way that best promotes and ensures consistency with the purpose.

## The inspection process

Certification Authorities will appoint Vehicle Inspectors to inspect a vehicle's self-containment facilities. Vehicle Inspectors will complete a record of the inspection and provide this to the Certification Authority so that they can decide whether to certify the vehicle as self-contained. Accordingly, it is important that vehicle inspections are carried out to a consistently high standard.

Certification Authorities must ensure that vehicle inspections they arrange are carried out in accordance with the Regulations, and with the Plumbers, Gasfitters, and Drainlayers Board (Motor Vehicle Inspections) Notice 2023 (**Notice**).<sup>2</sup> The Notice prescribes the minimum requirements in relation to what must be inspected and verified during an inspection (in accordance with the Regulations), and the technical details that must be recorded.

A copy of the Board's recommended vehicle inspection form can be accessed from the Board's [website](#).

It is expected that vehicle inspections will be carried out in-person. All vehicle inspections, regardless of how they are carried out, must meet the requirements contained in the Regulations and the Notice.

---

<sup>2</sup> [https://gazette.govt.nz/assets/pdf-cache/2023/2023-sl5545.pdf?2023-11-30\\_17%3A05%3A41=](https://gazette.govt.nz/assets/pdf-cache/2023/2023-sl5545.pdf?2023-11-30_17%3A05%3A41=)

## How to read this guidance

This guidance sets out the requirements and specifications contained in the Act and the Regulations in relation to the facilities vehicles must have to be certified as self-contained.

Guidance material is included within, and clearly indicated through use of, blue shaded boxes under the relevant requirements. This includes guidance on ways in which the requirements and specifications contained in the Act and the Regulations can be met, and practices which are advised or recommended.

Guidance material does not detract from, or otherwise alter, the effect of the requirements which are contained in the Act and the Regulations.

Vehicle Inspectors should contact their Certification Authority if they have any questions about the inspection requirements contained in the Notice, or whether a vehicle's facilities meet the requirements contained in the Act and the Regulations.

The following sections provide the guidance for Vehicle Inspectors and Certification Authorities on the requirements relating to the following facilities:

1. Water supply system and loading mechanism
2. Fixed toilets
3. Wastewater system and offloading mechanism
4. Ventilation system
5. Sink and rubbish storage
6. Maximum number of occupants

# 1. Water supply system and loading mechanism

A vehicle must have:

- a water supply system that stores and conveys water in a secure manner that prevents contamination of the water; and
- a means of loading water into the vehicle securely and in a way that does not contaminate that water.

**Applicable Regulations:** [r13\(a\) and \(e\)](#), [r14](#), [r16](#), [r19\(1\)](#).

## Water storage

To meet the requirements for self-containment, a vehicle's water supply system must include one or more water storage tanks:

- 1.1 of sufficient size, volume, and durability to be able to operate for a minimum of 3 days for the maximum number of occupants for which the vehicle is certified;

The water storage tank(s) may be fixed or portable, and should:

- have a capacity of not less than 4 litres per day for each occupant the vehicle will be certified for (i.e. a minimum capacity of 12 litres per person)
- have a larger capacity if there is a flushing toilet, or additional facilities connected to the water supply system (for example, shower, washing machine, or dishwasher), and
- be durable enough to remain operational with normal use.

The water storage capacity used to calculate the maximum number of occupants the vehicle can be certified for needs to be the capacity of the tank(s) fixed to or stored within the vehicle being certified. Vehicle owners may choose to store additional water supply outside of the vehicle (for example, in a towing vehicle).

Vehicles with larger portable tanks (for example, larger than 25 litres) should have a means to assist occupants to load the tank into the vehicle.

Refer to section 6 below for guidance on how to calculate the maximum number of occupants the vehicle can be certified for.

- 1.2 designed for the purpose of storing potable water, and installed and being used in a way that ensures the tanks remain functional for at least the period of certification (i.e. the water storage tanks are 'fit for purpose');

Water tanks should be designed to store potable water and to be connected to other elements of the water supply system to enable water reticulation.

Water tanks should be installed and secured as provided for in 1.7 below.

- 1.3 installed in a manner that avoids the likelihood of contamination within the system and uses components that will not contaminate the water;
- 1.4 made from suitable materials that will not contaminate water;
- 1.5 protected from the risk of deterioration from sun exposure, either by being made of a material that is resistant to ultraviolet (UV), or stored in a way that avoids exposure to sunlight;

Water tanks should be made of a non-toxic, opaque and UV-resistant material. For example, tanks may be made of UV-resistant or UV-stabilised, food grade polyethylene.

Where the water tank is not made of UV resistant material, or you can't confirm that materials are UV-resistant, the water tank must be stored in a way where it is not exposed to sunlight (for example, beneath the vehicle or stored in a false floor).

AS/NZS 4020:2018 is the standard for testing products in contact with drinking water in New Zealand and Australia and may assist if there is any doubt about the suitability of materials.

- 1.6 protected from the risk of the growth of legionella bacteria within the tanks, either by being located away from heating sources, or sufficiently insulated to prevent bacteria growth;

Legionella bacteria can be present in potable water supplies. Legionella bacteria thrive in temperatures between 20-50°C. Legionellosis (Legionnaires' disease) can affect vulnerable individuals who inhale airborne particles containing these bacteria from contaminated water sources.

As noted in paragraph 1.6 above, all water storage tanks that are not sufficiently insulated must be located away from heating sources, including the engine and the exhaust system. This is to prevent the water temperature in the tanks being affected by those heating sources under normal operating conditions for the vehicle.

If it's not possible to locate water storage tanks away from heating sources (or in addition to locating water tanks away from heating sources), water tanks must be sufficiently insulated from known heating sources.

The insulation must be sufficient to prevent the water temperature in the tank from being affected by heating sources under normal operating conditions of the vehicle. Insulation should be: made of an appropriate type of insulation material; have sufficient insulating qualities; and may include a divider or air gap to prevent heat transfer.

Additional ways vehicle owners may reduce the risk of legionella bacteria growth include (but which are not requirements for self-containment certification):

- If the vehicle has a storage hot water cylinder, setting the thermostat to a minimum of 60 degrees Celsius.
- Emptying water tanks when not in use. The system should be flushed after a period of not being used.
- Installing a suitable UV sterilisation device and filter.

- 1.7 adequately supported and secured to avoid creating any hazard while the motor vehicle is moving;

Having secured water storage tanks is important to ensure the safety of both vehicle passengers and other road users (for example, to prevent a projectile hazard while the vehicle is moving).

Water tanks (whether portable or fixed) must be secured so that they cannot move or break free from restraints whilst the vehicle is moving. All brackets, supports and fixings should be:

- sturdy and durable
- free from abrasions, degradation and (where applicable) structural rust or other corrosion
- free from the likelihood of premature wear due to vibration or vehicle movement, and
- made of UV-resistant material (if exposed to sunlight).

Larger tanks (i.e. tanks over 50 litre capacity) should have baffles fitted to prevent the surging of water in a tank which can cause fixings to fail prematurely and affect vehicle stability. The underside of the tank will be adequately supported to prevent sagging.

Portable tanks must be adequately supported and secured (for example, with straps or brackets). Restraints should be able to withstand a load four times the mass of the wastewater tank and its contents while the vehicle is moving.

- 1.8 constructed in a way that allows air to enter the tank in order to displace the water leaving the tank;

Proper venting will help to ensure displacement of water (for example, allowing water to leave the tank when the sink tap is used). Venting will also reduce the risk of the tank being damaged when being filled or emptied (i.e. preventing the tank deforming).

There should be sufficient ventilation to allow air movement while the potable water is being filled. The vent may also function as an overflow when filling the tank so that excess water is disposed of outside the vehicle.

Air vents should be protected to prevent contamination from external sources (including insects and other contaminants). For example, mesh or other fittings may be appropriate.

- 1.9 fitted (at the tank inlet) with a seal capable of preventing the entry of foreign matter into the tanks;

- 1.10 protected from contamination from external sources;



- 1.11 securely mounted and capped to avoid damage or leaks from water movement while the motor vehicle is moving;

Water inlets should be protected to prevent contamination from external sources (including insects and other contaminants). For example, water inlets should be securely sealed with a cap.

The recommended minimum diameter of the water inlet is:

- 25mm for a non-pressure fed tank
- 12mm for a pressure fed tank.

Water can be drawn from a mains system to fill the water tanks, or a clean hose that has been flushed and is appropriate for potable water. There may be a suitable inlet connection to attach the water supply.

Sanitary fittings should be supplied from the water supply in such a way that the return of water by backflow or cross connection to the supply tank is prevented. For example, where the water supply can be directly connected to the inlet, there should be a suitable backflow prevention device installed to prevent cross contamination.

Note: when using supplementary materials such as funnels and hoses for filling water tanks, they must not contaminate the water and should be suitable for use with potable water. For example, garden hoses are not generally designed or suitable for use with potable water and may contaminate the water.

The filling device(s) should be stored appropriately to prevent cross contamination.

## Water reticulation

To meet the requirements for self-containment, a vehicle's water supply system, including pipes, fittings, and other components that reticulate water, must:

- 1.12 be capable of reticulating water to the vehicle's other facilities;
- 1.13 be designed for the purpose or function of reticulating potable water, and installed and used in a way that ensures the water supply system remains functional for at least the period of certification (i.e. water supply system is fit for purpose);

For example, pipes, fittings, and other components that reticulate potable water must have been designed for that purpose, and not designed to convey wastewater or other types of liquids.

Installation must be appropriate and durable enough to ensure that the water supply system will be able to continue to reticulate water for at least the period of certification (i.e. four years).

See also 1.14 – 1.16 in relation to installation, and 1.17 and 1.18 in relation to suitability of materials.

- 1.14 be installed in a manner that avoids the likelihood of contamination within the system;
- 1.15 be protected from contamination from external sources;
- 1.16 be installed in a way that ensures they do not fail or leak at the system's design pressure;

One of the main sources of contamination may come from cross contamination hazards.

Cross connection hazards are any condition, material, device, or practice which, in connection with the potable water supply system could contaminate the water (for example, a blackwater tank cleaning wand that is in contact with potable water). Note: cross contamination hazards can be:

- low hazard: constituting a nuisance (for example, colour, odour, or taste)
- medium hazard: having the potential to injure or endanger health, or
- high hazard: having the potential to cause death.

The water supply system should supply sanitary fittings in a way that prevents the return of water by backflow or cross connection into the supply tank(s). Backflow protection should be suitable for the cross connection hazard, for example a suitable air gap is appropriate backflow protection for high hazards. G12/AS1 provides commentary on protection of potable water which may be helpful when considering backflow protection.<sup>3</sup>

Note: it can be helpful to label the inlet.

Pipes should be installed or stored away from heating sources to reduce the risk of legionella and to prevent damage.

- 1.17 be made from suitable materials, and installed using components that will not contaminate the water;
- 1.18 include pipes and fittings that are made of an opaque material that is suitable for contact with potable water;

Clear pipes which are exposed to light are prone to algae growth which discolours the water and may be harmful. Pipes and fittings must therefore be opaque (i.e. completely non-transparent) to prevent light ingress, and must be made of materials designed for reticulating potable water (for example, a garden hose pipe is highly unlikely to meet the requirements in this section).

Notably, materials in contact with potable water should have less than 0.25% lead by weighted average.

It won't always be easy to identify the type of materials a pipe is made of and whether those materials are suitable for contact with potable water. Markings on the pipes may indicate the type of material and whether it's suitable.

---

<sup>3</sup> Adapted from the Ministry of Business, Innovation and Employment, *Acceptable Solutions and Verification Methods for New Zealand Building Code Clause - G12 Water Supplies*. Available at: [www.building.govt.nz/assets/Uploads/building-code-compliance/g-services-and-facilities/g12-water-supplies/asvm/g12-water-supplies-3rd-edition-amendment-12.pdf](http://www.building.govt.nz/assets/Uploads/building-code-compliance/g-services-and-facilities/g12-water-supplies/asvm/g12-water-supplies-3rd-edition-amendment-12.pdf)

G12 lists several relevant pipe manufacturing standards, and AS/NZS 4020:2018 is the standard for testing products in contact with drinking water in New Zealand and Australia. Both resources may assist if there is any doubt about the suitability of materials.

- 1.19 be installed in a manner that pipes water to sanitary fixtures (such as toilets, showers, and sinks) and sanitary appliances (such as dishwashers) at flow rates that are adequate for the correct functioning of those fixtures and appliances under normal conditions.

Pipe size will affect flow rates and the requirements will vary depending on the pressure of the water and the requirements of the individual fixtures. Flow rates should be checked by observing water flow to fixtures and appliances.

## 2. Fixed toilets

A vehicle must have a fixed toilet that collects human waste securely and hygienically.

**Applicable sections of the Act:** [s87U\(4\)\(a\)](#)

**Applicable Regulations:** [r13\(b\)](#), [r14](#), [r17](#), [r18\(3\)](#)

To meet the requirements for self-containment, a vehicle must have at least one toilet that:

- 2.1 is of sufficient size, volume, and durability to be able to operate for a minimum of three days for the maximum number of occupants for which the vehicle is certified;

Blackwater tank capacity should be sufficient to safely store the volume of wastewater entering it. Blackwater tank capacity should be a minimum of one litre per person, per day.

Toilets will also need to be sufficiently durable (see below at 2.5 – 2.7 which provides guidance relating to materials and installation requirements).

Refer to section 6 below for assistance when calculating maximum number of occupants.

- 2.2 is usable within the vehicle;

To be usable within the vehicle, toilets should have adequate height clearance and elbow room. Recommended clearance dimensions are shown in Figures 1 and 2 below (noting that slightly smaller dimensions than those indicated may still meet the requirements).

Figure 1: Clearance for toilet space

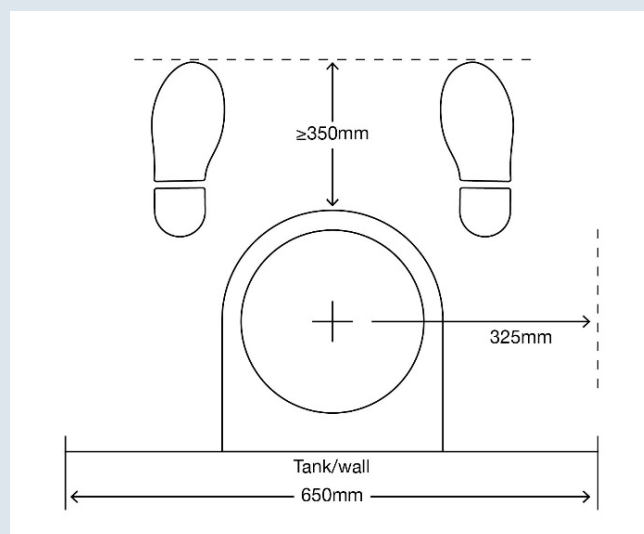
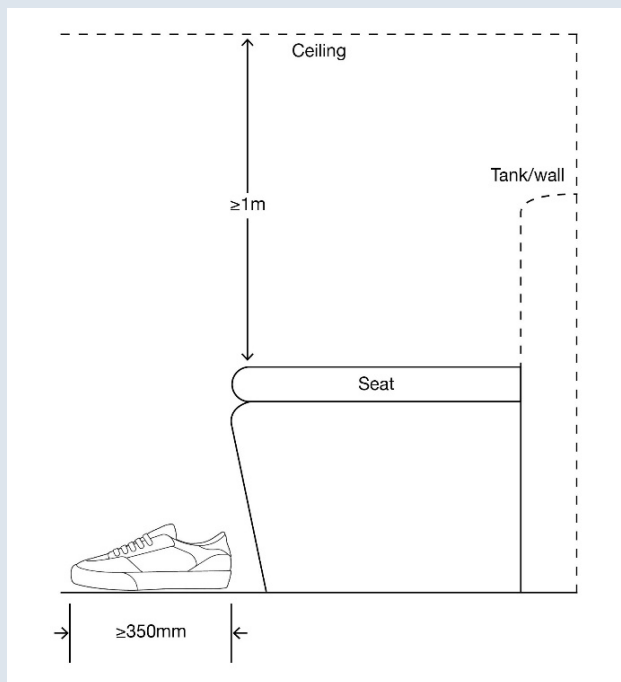

Figure 2: Clearance for toilet space (side view)



- 2.3 is permanently fixed to the vehicle with the base of the toilet rigidly mounted in position and does not require removal in order to empty human waste;

'Permanently fixed' includes that the toilet must be incapable of removal from the vehicle without disassembly.

The toilet will be permanently installed, moulded or built into the vehicle in accordance with the toilet manufacturer's instructions and (or where there are no instructions) in accordance with good trade practice.

The base of the toilet must be rigidly mounted in position (permanently fixed to the vehicle) and must not require removal in order to empty human waste.

A toilet may meet these requirements even if it has some degree of adjustability. For example, a swivel-type toilet or a toilet appropriately fixed to the vehicle using heavy duty rails may meet the requirements if it is permanently fixed to the vehicle with the base rigidly mounted in position and does not require removal to empty human waste.

Note: such toilets will need to meet all other toilet requirements, including those contained in this section (section 2), wastewater requirements (section 3) and ventilation requirements (section 4).

Portable toilets, and other toilet configurations requiring the toilet to be disassembled or the base to be removed from the vehicle in order to empty human waste (for example, some types of composting waterless toilets), will not meet the requirements of this section.

Note: all toilets (including cassette-type toilets) must meet the specific requirements relating to wastewater storage tank ventilation and offloading - see section 4 and 3.10–3.12 below.

2.4 drains or flushes directly into a suitably designed and fitted blackwater tank or a removable blackwater holding tank;

If the toilet doesn't drain or flush into a suitably designed and fitted blackwater tank, it must drain or flush into either:

- a removable cassette that is compatible with the toilet (if the toilet is a cassette-type toilet), or
- a removable chamber (if the toilet is a waterless toilet).

'Suitably designed' includes that the blackwater tank (whether it is fixed or removable) or chamber has been designed for securely and hygienically storing human waste.

Note: Fixed blackwater tanks must have an isolating valve that allows the wastewater system to be safely emptied. This stops the flow of wastewater so that the tank can be safely emptied. For further information see section 3 on the Wastewater system.

Wastewater pipes and valves from the toilet to the blackwater tank should have a minimum diameter of 75mm, or where a macerator pump is used, a minimum diameter of the discharge pipe and valve should be 32mm.

2.5 is constructed from suitable fittings and materials;

The toilet must be constructed from suitable fittings and materials, which will include materials designed to be exposed to and store human waste, and which are non-toxic, non-corrodible, and stable. G13 lists several relevant pipe and fitting manufacturing standards. This may assist if there is any doubt about the suitability of materials.<sup>4</sup>

2.6 is installed in a sound and appropriate manner;

As noted at 2.3 above, the toilet will be permanently installed, moulded or built into the vehicle in accordance with the toilet manufacturer's instructions and (or where there are no instructions) in accordance with good trade practice.

Fixings used to install the toilet should be appropriate for their application and the installation method should not compromise or otherwise affect the structural integrity or functioning of the toilet (or vehicle).

A toilet that is not designed to be permanently fixed to a vehicle, but where attempts have been made to fix or install the toilet in a way in which it was not designed or intended for use is unlikely to meet the requirements (for example, portable toilets which have been screwed or bolted in place so as to be 'fixed' are highly unlikely to meet the requirements in this section).

---

<sup>4</sup> Ministry of Business, Innovation and Employment, *Acceptable Solutions and Verification Methods for New Zealand Building Code Clause - G13 Foul Water*. Available at: <https://www.building.govt.nz/building-code-compliance/g-services-and-facilities/g13-foul-water/>

## 2.7 is fit for purpose;

A toilet will be fit for purpose if it:

- meets the requirements in this section
- is a fixed toilet that collects human waste securely and hygienically
- has been installed in accordance with manufacturers' instructions where applicable, or otherwise in accordance with good trade practice, and will remain functional for at least the period of certification (i.e. four years)
- functions and operates in accordance with its intended use
- has been designed for the purpose or function for which it will be used i.e. a fixed toilet.

Note: Many marine toilets are a backflow risk when connected to the potable water supply. Where marine toilets provide a cross connection hazard they should have:

- their own supply tank, or otherwise re-circulated (filtered) water from the waste tank; or
- a properly functioning backflow prevention device suitable for the hazard.

Marine type toilets must meet the other requirements contained in this section.

Note: See also ventilation requirements that apply to a vehicle's wastewater (blackwater and greywater) storage tanks at section 4 below.

## 3. Wastewater system and offloading mechanism

A vehicle must have:

- a wastewater system that both stores and collects greywater and blackwater securely and hygienically
- a means of disposing of wastewater hygienically to an appropriate outfall.

Applicable Regulations: [r13\(c\)](#), [r14](#), [18](#), [19](#)

### Wastewater tanks and system

To meet the requirements for self-containment, a vehicle's wastewater system must:

- 3.1 either store greywater and blackwater separately or, if greywater and blackwater are combined, stores them as blackwater;

A vehicle's wastewater tank(s) can be fixed or portable. The tanks must meet the requirements in this section.

Note: In accordance with the Regulations, the cassette from a cassette-type toilet is a wastewater storage tank. See also ventilation requirements that apply to a vehicle's wastewater (blackwater and greywater) storage tanks at section 4 below.

- 3.2 if the vehicle stores greywater and blackwater as combined, store the blackwater in either:

- 3.2.1 removable cassettes that are compatible with the motor vehicle's toilet; or
- 3.2.2 one or more fixed tanks that have an isolating valve that allows the system to be emptied safely;

Wastewater that combines greywater and blackwater must be stored as blackwater.

See also 2.4 above in relation to the suitability of blackwater tanks.

- 3.3 if the vehicle stores greywater **separately** from blackwater, store greywater in either:

- 3.3.1 one or more fixed tanks that are connected to the motor vehicle; or
- 3.3.2 one or more portable tanks that are connected to the motor vehicle;

Storage of greywater and blackwater can be separate or combined. If combined, all greywater must then be treated as blackwater.

A vehicle may have a removable greywater tank provided the waste pipe that feeds the tank has an isolating valve and cap.



There should be a watertight seal between the greywater tank (including portable tanks or connecting hoses) and the connecting pipe of the vehicle.

For portable tanks the recommended maximum size is approximately 25 litres (due to risk of strain when lifting). For larger tanks there should be a means to help load it.

- 3.4 be of sufficient size, volume, and durability to be able to operate for a minimum of three days for the maximum number of occupants for which the vehicle is certified;

The wastewater tank(s) should:

- have a capacity of not less than the capacity of the water supply tank(s) i.e. a minimum of 12 litres per person
- be durable enough to be able to withstand wear from normal use of the tank(s).

Greywater tank capacity needs to be sufficient to handle the flow of water (it could overflow with a small tank). Note: a monitor, gauge (or eyeglass) can be fitted to the greywater tank to monitor and prevent overflow into the vehicle.

Refer to section 6 below for assistance when calculating maximum number of occupants.

- 3.5 have water drainage pipes that are a sufficient size, watertightness, and gradient to allow for the effective and convenient egress of wastewater from any sinks, basins, and showers into greywater storage;

Waste pipes should be suitable for the flow of water going into them. Waste pipes should be a minimum diameter of 20mm from a sink, hand basin, shower or other fitting. Larger diameter pipes should be used to aid efficient draining, when appropriate.

The gradient must be sufficient to allow wastewater from fixtures to drain to greywater tanks.

The wastewater pipes should not have any slumps, as this could cause waste to gather and create a blockage in the system. Wastewater pipes may still meet this requirement if an intentional slump is used to form a water trap (noting it must allow for the effective and convenient egress of wastewater). However, best practice is to use a fixture trap as these can be more easily maintained in the event of a blockage.

Pipes should be inspected for signs of leaks or dampness. One way to do this is to ask customers to come to the inspection with a full greywater tank.

Waste pipes should be supported and located away from where they can be easily damaged. For example, wastepipes should not be located below the chassis where they can be damaged by speed bumps.

- 3.6 safely and reliably conveys wastewater from the vehicle's facilities to storage tanks and securely stores wastewater until the tanks or vessels are emptied;

The vehicle's wastewater tanks should receive the wastewater from all permanently installed fixtures.

- 3.7 be constructed from fittings and equipment made from suitable materials;

All appliances, fixtures, fittings, tanks, pipes, pipe fittings, and valves used in the wastewater system must be made from non-toxic, non-corrodible, and stable materials.

G13 lists several relevant pipe and fitting manufacturing standards. This may assist if there is any doubt about the suitability of materials.

- 3.8 be designed for the purpose and function of safely and reliably conveying wastewater from the vehicle's facilities to storage tanks or vessels until they are emptied, and installed and used in a way that ensures the wastewater system is functional for at least the period of certification (i.e. the wastewater system is 'fit for purpose');

- 3.9 be installed in a sound and appropriate manner, including:

3.9.1 tanks are securely mounted and capped to avoid damage or leaks from water movement while the vehicle is moving; and

3.9.2 appliances, fixtures, fittings, tanks, and pipes used in wastewater system are securely fixed or fastened;

Having secure wastewater tanks is important to ensure the safety of both vehicle passengers and other road users (for example, to prevent a projectile hazard while the vehicle is moving).

Wastewater tanks, whether portable (including rollaway tanks) or fixed, should be installed or secured so they cannot move or break free from restraints whilst the vehicle is moving. All brackets, supports and fixings should be:

- sturdy and durable
- free from abrasions, degradation and (where applicable) structural rust or other corrosion
- free from the likelihood of premature wear due to vibration or vehicle movement
- made of UV-resistant material (if exposed to sunlight).

All pipes, fittings and other components that make up the wastewater system must also be securely fixed or fastened to the vehicle.

Portable (including rollaway) wastewater tanks should have secure caps (both inlet and outlet) to avoid spillage during transport to a dump station.

Portable tanks must be adequately supported and secured (for example, with straps or brackets). Restraints should be able to withstand a load four times the mass of the wastewater tank and its contents while the vehicle is moving.

## Offloading mechanism

To meet the requirements for self-containment, a vehicle must include a means of disposing of wastewater hygienically to an appropriate outfall, including:

- 3.10 any wastewater pipes and hoses are of sufficient size, strength, and durability in order to ensure the clean, convenient, and safe discharge of the wastewater;

The waste evacuation valve and connection point should be on the outside of the vehicle to avoid spills in the vehicle.

Waste outlets should have secure caps to prevent waste leaking during transit or transport to a dump station.

Blackwater tank outlets should have a minimum diameter of 25mm, and non-pumped a minimum diameter of 40mm.

The discharge hose should be long enough to allow access to the transfer/dump station. Generally, discharge hoses will be approximately 3 metres long but shorter hoses may be sufficient (and reduce risk of wastewater pooling in the hoses and spillage). Note: offloading should be done at an approved dump station.

- 3.11 the motor vehicle must have appropriate storage for the pipes and hoses used to discharge wastewater that minimises the health risks associated with residual contaminants on the pipes and hoses (if applicable);

Offloading equipment (for example, evacuation hoses, wastewater hoses and spare wastewater tanks) should be stored and stowed separately from filling equipment. For example, offloading equipment should be stored in a compartment that is accessible from the outside of the vehicle.

Note: labelling wastewater equipment (for example, outlet hoses and tanks) can help to prevent cross contamination.

- 3.12 the motor vehicle must have sufficient facilities for the safe and secure offloading of waste from a waterless toilet (if applicable).

Waterless toilets should allow for secure and hygienic removal of waste from the toilet.

See 2.4 and 4.3.3 for further guidance on waterless toilets.

**Note:** See section 4 below containing requirements for wastewater storage tank ventilation.

## 4. Ventilation system

A vehicle must have a ventilation system that removes odours from the vehicle and minimises the extent to which foul air and gases can enter the vehicle.

**Applicable Regulations:** [r13\(h\)](#), [r14](#), [20](#)

To meet the requirements for self-containment, a vehicle must have a ventilation system that:

- 4.1 ensures unpleasant or unhealthy odours and foul air can easily escape to the exterior of the motor vehicle;

A ventilation system is intended to prevent the build up of foul odours and to maintain comfortable temperatures inside the vehicle. It could refer to openable windows, grills and/or a mechanical ventilation system.

If mechanical ventilation is relied on (for example, an extractor fan), there should be sufficient power. For smaller vehicles, there should be at least one opening window or roof vent to adequately ventilate the vehicle.

Where the vehicle has a canopy, the vent should terminate away from the canopy to prevent foul smells from entering.

- 4.2 ventilates wastewater storage tanks directly to the exterior of the motor vehicle to ensure that foul air and noxious gases do not accumulate inside the tanks; and
- 4.3 includes vent outlets for wastewater storage tanks that:
  - 4.3.1 are installed at a height that safely prevents wastewater leakage; and
  - 4.3.2 terminate outside the motor vehicle and away from doors, windows or openings; and
  - 4.3.3 are fitted with a means to prevent the entry of birds and vermin into the system;

The Regulations require that wastewater storage tanks (including cassettes from a cassette-type toilet) are ventilated directly to the exterior of the vehicle.

Where possible, vent outlets should terminate either through the roof or near the roofline, away from doors, windows or other openings. This helps prevent foul odours and gases from becoming a nuisance. If vent outlets aren't positioned near the roofline, they should extend above the flood level of the lowest sanitary fitting.

The vent outlet diameter should be a minimum of 12mm and should be suitable for the fixtures attached to it.

A hooded cowl can be fitted to prevent entry of birds, vermin or rainwater.

If the waste tank uses a macerator pump or waste evacuation hose larger than 50mm diameter the system should be fitted with an automatic air admittance valve or a vent of no less than 32mm diameter.

Where the length of the waste pipe exceeds 3.5 metres, the pipe should be vented or fitted with an air admittance valve. The vent pipe or air admittance valve is to aid in water flow and prevent the water seal from being siphoned.

- 4.4 includes pipes connecting sanitary appliances and sanitary fixtures to wastewater storage tanks that are fitted with a means of limiting the escape of foul air and noxious gases from the tanks to the interior of the motor vehicle, such as a water trap;

Every waste pipe draining every sanitary fitting should have a water trap seal located as close as possible to the fixture that it serves (for example, no more than 1 metre away). This is to prevent foul air and/or gases from entering the vehicle.

The water seal depth should be sufficient to prevent foul air and gases from entering the vehicle. The recommended minimum depth is 40mm, but other specialty designed traps (with a smaller water seal depth) may also meet the requirements.

The water seal trap may include an automatic air admittance valve (to prevent siphon of the water seal).

A waste non-return valve can also be suitable. Note: check to ensure there are no obstructions preventing it from sealing (for example, obstructions such as hair can get caught in the seal allowing for foul air and gases to pass through).

Any air admittance valve should terminate above the water seal. The branch to the air admittance valve should be within 200mm of the water seal.

Where the length of the waste pipe exceeds 3 metres the diameter of the pipe should be a minimum of 25 mm diameter.

- 4.5 is of sufficient size, volume, and durability to be able to operate for a minimum of three days for the maximum number of occupants for which the vehicle is certified;

The ventilation system must be sufficient to operate as designed for a minimum of three days for the maximum number of occupants the vehicle will be certified for. Refer to section 6 below for assistance when calculating maximum number of occupants for the ventilation system.

- 4.6 is designed for the purpose of ventilating, and installed and being used in a way that ensures the ventilation system remains functional for at least the period of certification (i.e. the ventilation system is 'fit for purpose');

Any ventilation fans fitted should be designed for that purpose, and installed suitably so as to continue to operate for at least the period of certification (i.e. four years).

- 4.7 is made from suitable materials, including that any fixtures, fittings, pipes, pipe fittings, and valves used for ventilation in the wastewater system are non-toxic, non-corrodible, and stable materials; and

- 4.8 is installed in a sound and appropriate manner, including in particular that any fixtures or fittings used for ventilation in the wastewater system are securely fixed or fastened.

Ventilation equipment connected to the wastewater tank(s) and system (including fixtures, fittings, pipes, pipe fittings, and valves) must be non-toxic, non-corrodible, and stable.

G13 lists several relevant pipe and fitting manufacturing standards. This may assist if there is any doubt about the suitability of materials.

## 5 Sink and rubbish storage

A vehicle must have:

- a sink that is installed safely and drains to the wastewater system's tank
- secure rubbish storage.

**Applicable Regulations:** [r13\(d\) and \(g\)](#), [r14](#), [r16 \(c\) \(iii\)](#), [r18 \(i\) \(c\)](#)

To meet the requirements for self-containment, a vehicle's sink and rubbish storage must be:

- 5.1 of sufficient size, volume, and durability to be able to operate for a minimum of three days for the maximum number of occupants for which the vehicle is certified;
- 5.2 designed for the purpose or function for which they have been or will be used;
- 5.3 installed in a sound and appropriate manner, including being securely fixed or fastened, and in a way that ensures they remain functional for at least the period of certification; and
- 5.4 made from suitable materials, which for the vehicle's sink means being constructed from fittings or items of equipment that are non-toxic, non-corrodible, and stable materials.

### Sink

- 5.5 A vehicle must have a sink that is installed safely and drains to the wastewater system's tank.

Sinks should be appropriately fixed, sized, sealed, and connected to an appropriate wastepipe that allows drainage to the wastewater system's tank. The sink (and its fittings and pipes) must be securely fixed and fastened.

Additional fittings (for example, a shower) are optional.

Sinks should be suitable for their intended use. For example, sinks should be of sufficient size to wash dishes.

## Secure rubbish storage

### 5.6 A vehicle must have secure rubbish storage.

The rubbish container should be in a sealable container to prevent leaking, odours and spills.

As noted in 5.1 above, the rubbish container must be of a sufficient size, volume and durability to contain the rubbish for a minimum of three days for the maximum number of occupants the vehicle will be certified for. For example, this could include a bin with a locking mechanism, or flip top/push down lid style. A bag (for example) proposed for use on its own for the storage of rubbish is unlikely to meet the requirements in this section.

In general, rubbish bins should have a minimum capacity of approximately one litre per person per day. Having a secured (or otherwise adequately and safely stowed) rubbish container is important to ensure the safety of both vehicle passengers and other road users to prevent a projectile hazard while the vehicle is moving.



## 6 Maximum number of occupants

To meet the requirements for self-containment, the vehicle's facilities must be of sufficient size, volume, and durability to be able to operate for a minimum of three days for the maximum number of occupants for which the vehicle is certified.

**Applicable Regulations: [r14 \(1\) \(a\)](#)**

The following table shows the recommended minimum capacity of potable water, greywater and blackwater storage capacity for a three-day period.

Number of occupants certified for	1	2	3	4	5	6	7	8
Potable water storage (Litres)	12	24	36	48	60	72	84	96
Greywater storage tank (Litres)	12	24	36	48	60	72	84	96
Toilet cassette or blackwater tank (Litres)	3	6	9	12	15	18	21	24

The maximum occupants equals the minimum number of people any of the facilities allow for (for example, if the grey water tank is suitable for up to six occupants but the drinking water is only suitable for up to three occupants, then the vehicle can be certified for three occupants).

The ventilation system, loading and offloading mechanisms, sink and rubbish capacity also need to be adequate for the number of occupants the vehicle is being certified for. This requirement may be met if those facilities otherwise meet the requirements contained in the sections above.

The maximum number of occupants can be informed by the manufacturer's instructions when calculating the waste holding capacity for blackwater.

If a facility installed within the vehicle is likely to use a large amount of water, this should be taken into consideration when calculating the maximum number of occupants the vehicle can be certified for. For example, if a washing machine or dishwasher is installed in the vehicle, you should allow for one cycle of the machine in the three-day period, noting the manufacturers specifications relating to water usage (on average either appliance uses approximately 60 litres of water per cycle).

## Appendix 1: Definitions

Term	Definition
<b>Blackwater</b>	Any water or other material discharged from a fixture that is used to receive, process, or discharge human excrement
<b>Cassette toilet</b>	A fixed toilet with a removable (cassette) wastewater storage tank
<b>Greywater</b>	Any water, other than blackwater, discharged from a fixture (for example, a sink)
<b>Macerator pump</b>	A hand or electric powered pump which pulverizes and removes waste from a toilet
<b>Motor vehicle</b>	A vehicle drawn or propelled by mechanical power, or A trailer, or A unit used for camping that is not itself a vehicle but is capable of being— (i) transported by means of being loaded onto a vehicle; and (ii) used for camping whether it is loaded onto a vehicle or not
<b>Opaque</b>	Completely non-transparent, does not let light in
<b>Potable water</b>	Water that is fit for human consumption
<b>Wastewater</b>	Any blackwater and/or greywater, and includes solid waste material from a waterless toilet
<b>Wastewater system</b>	The pipes and other fixtures that transport wastewater from the place where water is received or used to the place where it is ultimately discharged

